

**D** darshana®

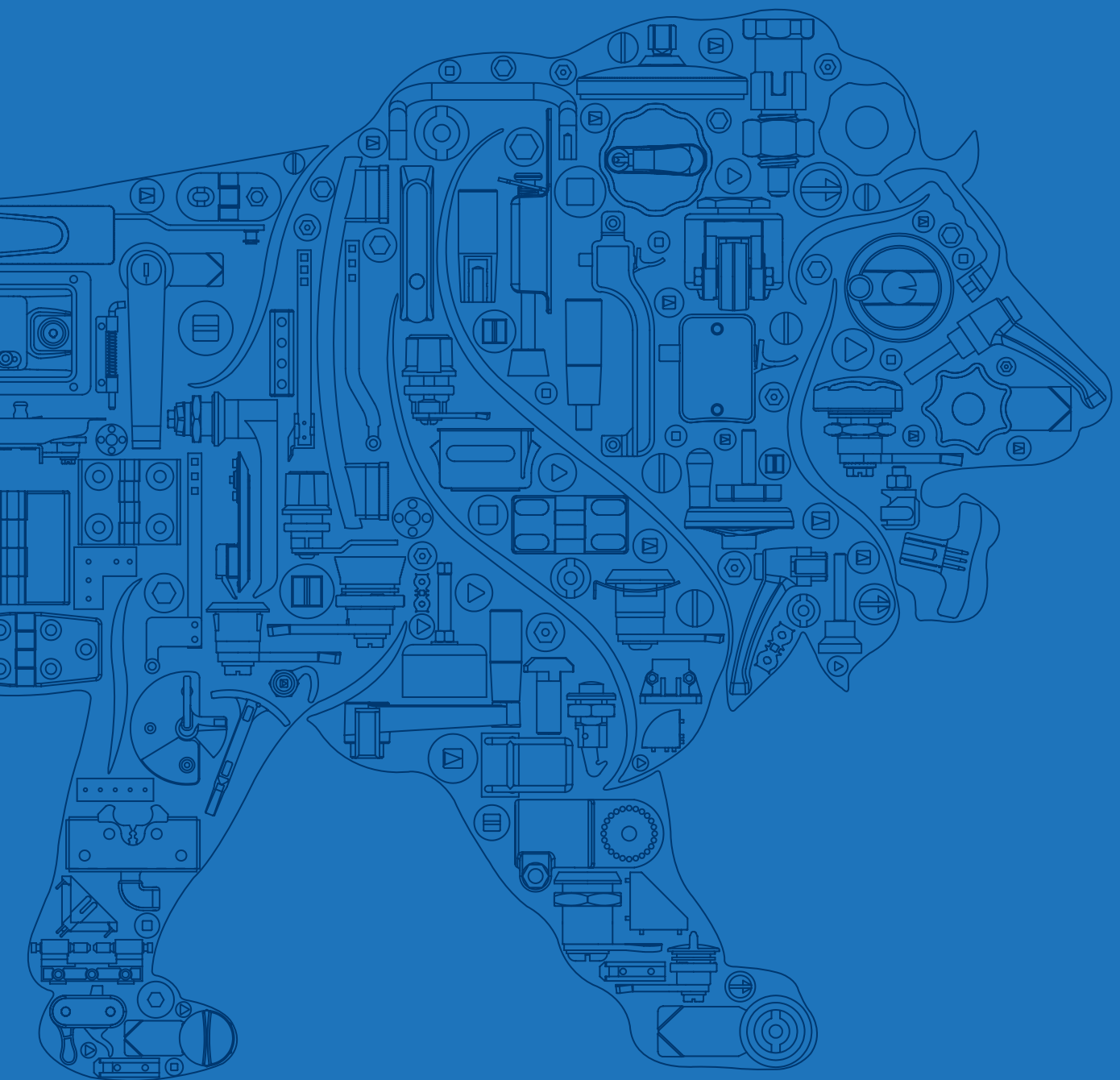

Made in India  Made for You



# WHO WE ARE

India's Largest and Most Trusted Manufacturer of  
Access Hardware and Machine Components

Founded in  
**1982**

Highly focused on  
**INDIA'S**  
Strong Machine  
Building Industry

Engineering

Tooling

Manufacturing

Sales

Two Locations in  
**PUNE**

120,000 sq. ft.  
(11,000 sq. m.)  
**AREA**

## OVER 350

People Committed to Customer Satisfaction

## OVER 20 DEALERS

in India and reliable partners overseas to provide end to end  
integration of parts in customer's designs

## OVER 90%

of components used are

## MADE-IN-HOUSE

Ensures control of quality and delivery

### OUR PRESENCE IN VARIOUS SECTORS



Agriculture



Airline Industry



Automation



Automobile



Dairy



Defence



Earthmoving



Electric Panels



Food



Generator



Hospital Essentials



HVAC



Interior



Kitchen Equipment



Machine Building



Marine



Medical



Office Furniture



Pharma



Printing & Packing



Railways



Renewable Energy



Telecom



Waste Management

# OUR GLOBAL PRESENCE

## India

- Ahmedabad
- Aurangabad
- Bengaluru
- Chennai
- Coimbatore
- Delhi
- Goa
- Hyderabad
- Indore
- Kolhapur
- Mumbai
- Nagpur
- Nashik
- Noida
- Pune
- Punjab
- Rajkot
- Surat
- Vadodara

## International

- Australia
- Canada
- Egypt
- France
- Iceland
- Ireland
- Israel
- Italy
- Kenya
- Kuwait
- Lebanon
- Malaysia
- Netherlands
- New Zealand
- Nigeria
- Oman
- Philippines
- Poland
- Saudi Arabia
- South Africa
- Spain
- Sri Lanka
- Thailand
- UAE
- United Kingdom
- Yemen
- Zambia
- USA

## Vision

To be the leading trusted source of engineered machine components.

## Mission

To create continuous growth opportunities through value driven product designs and operations.  
We will achieve this growth through well engineered designs that ensure product reliability and efficient manufacturing operations that are committed to quality, consistency, and cost management  
Customer connectivity that creates long-term relationships

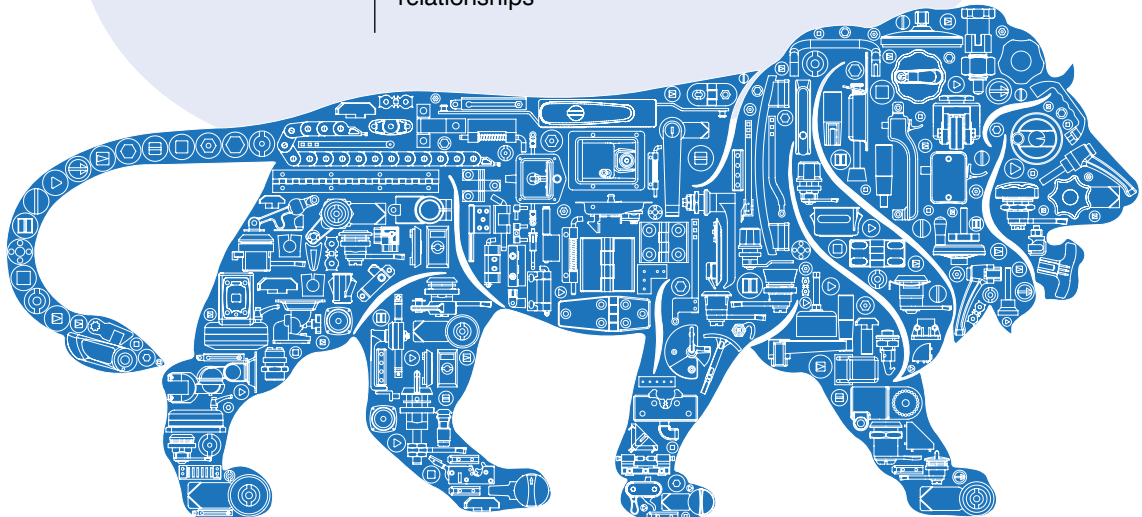

Made in India  Made for You



## Primary Processes in Facility 1

- Zinc Die Casting
- Injection Molding
- Powder Coating
- Laser Cutting
- CNC Machining
- Gasketing
- Key Making
- Robotic Welding
- Robotic Buffing
- Automated Assembly Lines

ISO CERTIFIED



9001 : 15 | 14001 : 15 | 45001 : 15

## Primary Processes in Facility 2

- Stamping Unit
- Riveting Line
- Secondary Finishing Lines
- Assembly (Sheet Metal Components)
- Space for expansion

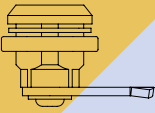
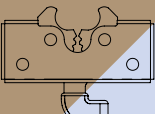
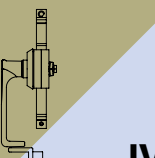
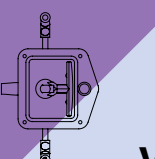

# Product Categories

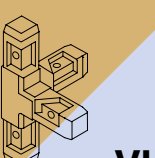
Colour coding for Category identification	Product Category	Category Sub Colour Shade	Page No.
 I	<b>HANDLES</b>		008 to 083
 II	<b>LOCKS</b>		084 to 119
 III	<b>LATCHES</b>		120 to 145
 IV	<b>MULTI-POINT LOCKS</b>		146 to 179
 V	<b>CANOPY LOCKS</b>		180 to 195
 VI	<b>HINGES</b>		196 to 267
 VII	<b>CONVEYOR COMPONENTS</b>		268 to 291

# Part Code Configurator



For building the **Part Code** please fill the variables that are outlined values from the table referring the drawings.

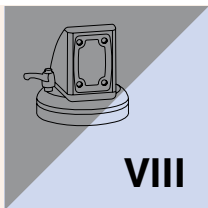

## SUPPORT ARM SYSTEM

292 to 323

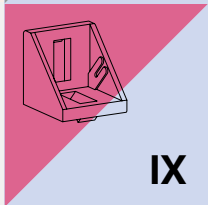

## ALUMINIUM SECTIONS & ACCESSORIES

324 to 343

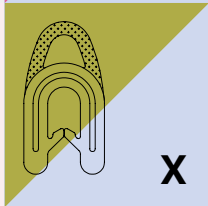

## GASKETS

344 to 349

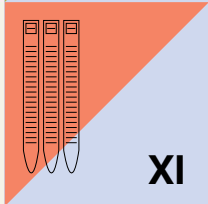

## CONDUIT ACCESSORIES & CABLE TIES

350 to 355

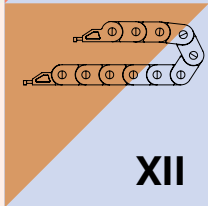

## DRAG CHAINS

356 to 361

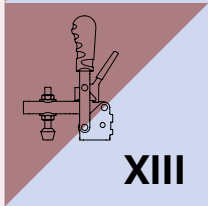

## TOGGLE CLAMPS

362 to 379

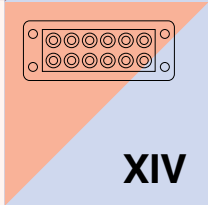

## CABLE MANAGEMENT SYSTEM

380 to 385

# Part Code Index

Product Name	Material	Page
Conduit Accessories	Polyamide	352
		353
Cable Ties		354
355		

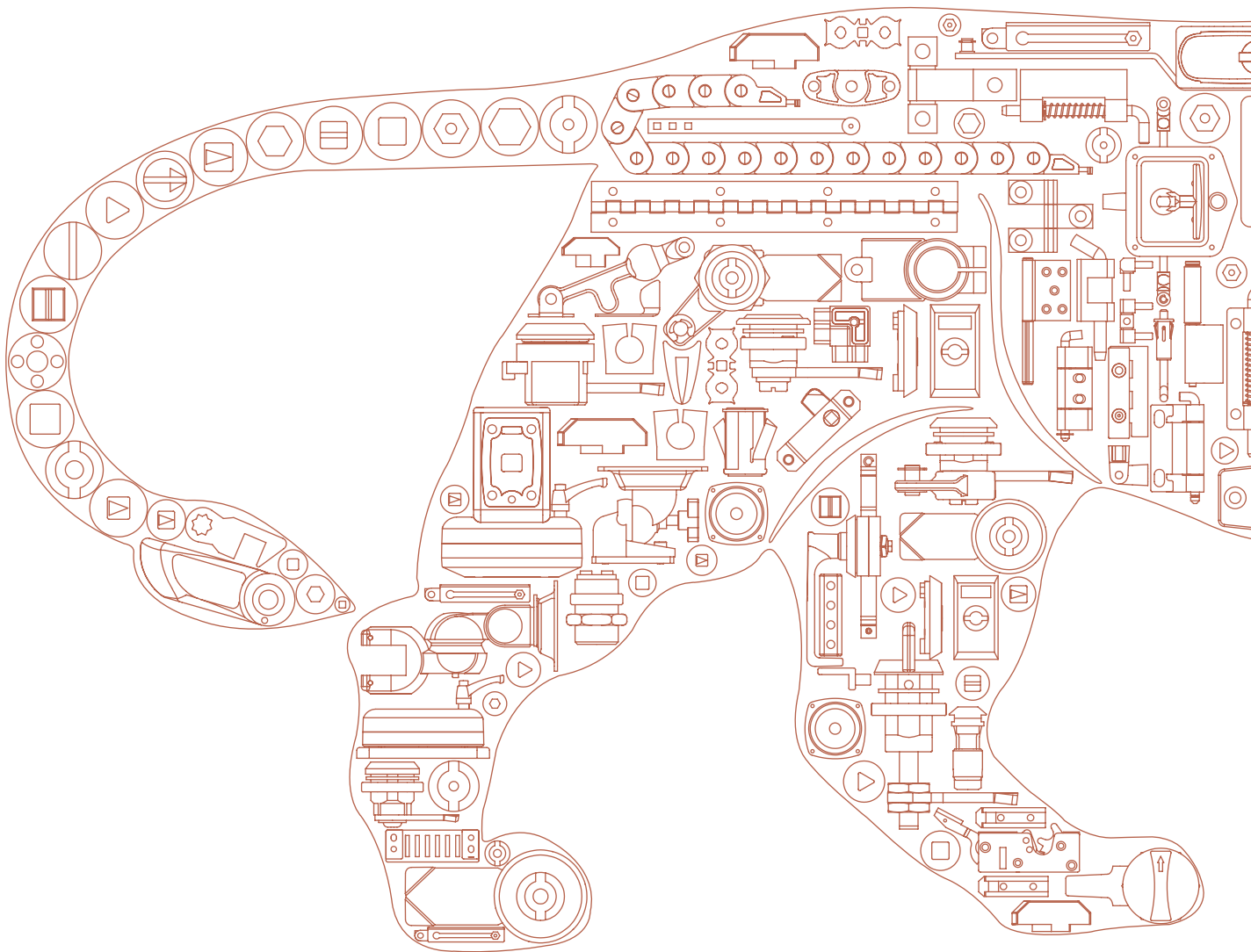



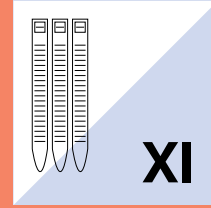

# CONDUIT ACCESSORIES & CABLE TIES

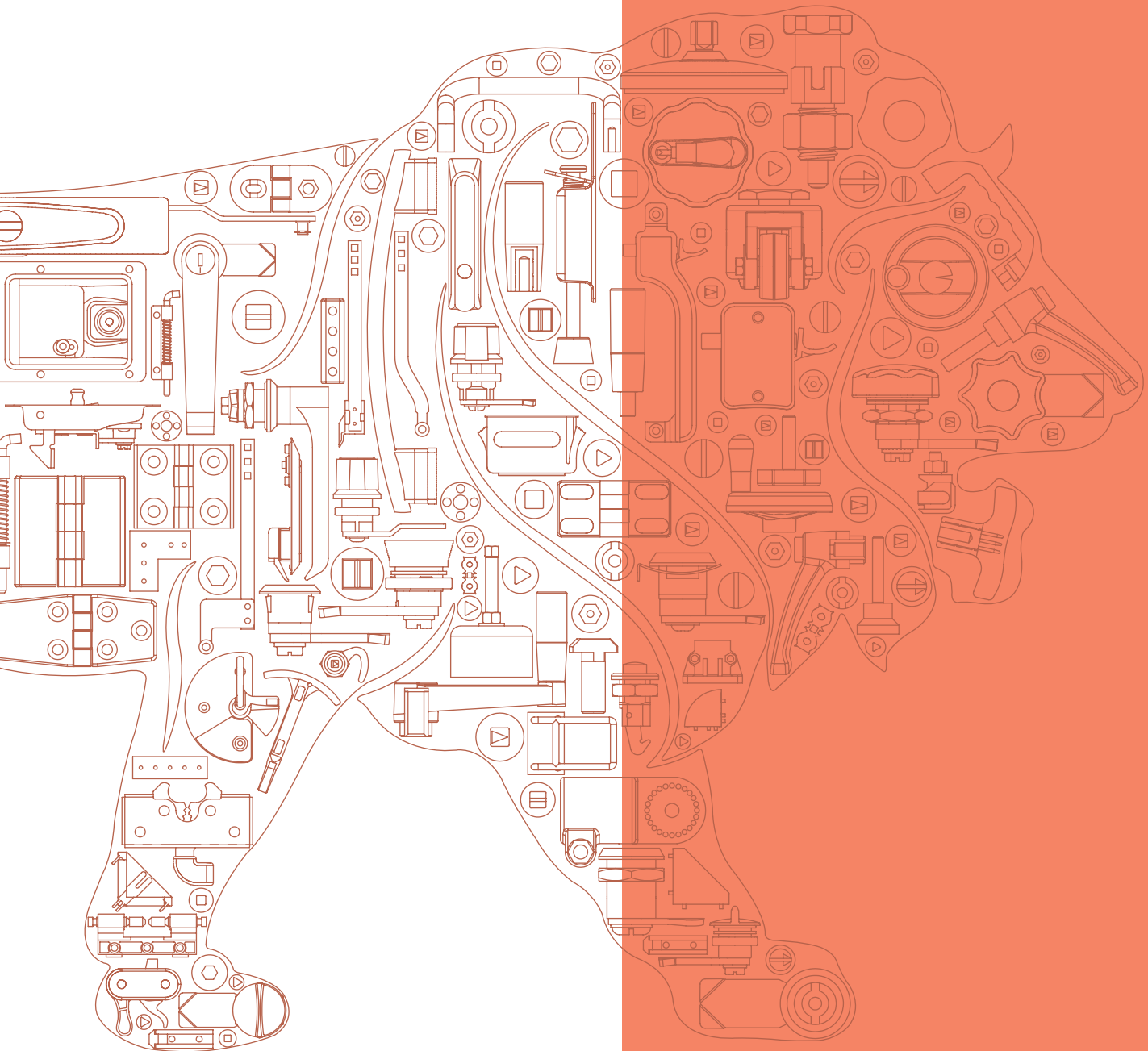

Made in India  Made for You

# CONDUIT ACCESSORIES & CABLE TIES

Conduit Accessories

Polyamide

XI

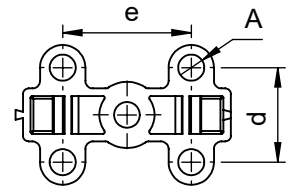
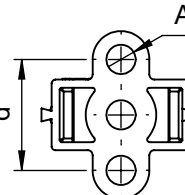
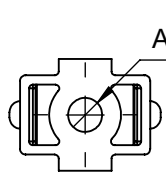
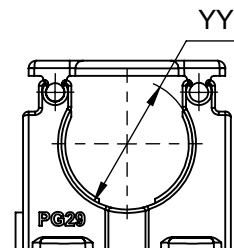
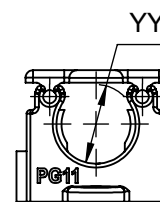
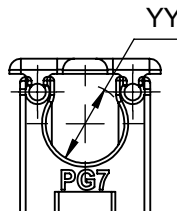
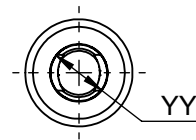
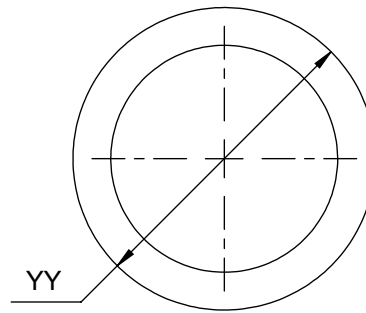

**D C P A - X - PG - YY**

- X** Accessory
- P** Pipe
- C** Clamp
- G** Gland

A(C)	A(G)	YY(C)	YY(G)	YY(P)	d(C)	e(C)
Ø4.5	Ø12.7	Ø10.4	Ø11.43	Ø10		
Ø5	Ø14.03	Ø12.7	Ø14.20	Ø12.5		
Ø5.8	Ø16.5	Ø15.7	Ø16.5	Ø15.5	22	
Ø5.6	Ø18.83	Ø18.2	Ø19.23	Ø18	23	
Ø6	Ø20.86	Ø21.3	Ø22.26	Ø21	23.5	
Ø6.2	Ø27.45	Ø28.3	Ø29.35	Ø28		
Ø6.9	Ø34.83	Ø34.7	Ø36.58	Ø34.5	25	34
Ø6.8	Ø46.05	Ø42.4	Ø44.55	Ø42.2	26.6	37.2
	Ø57.78	Ø53.5	Ø55.6	Ø53.3	26.8	56



# CONDUIT ACCESSORIES & CABLE TIES

Cable Ties

Polyamide

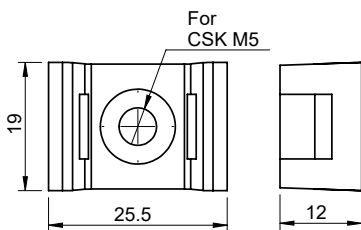

**A C H - 5**

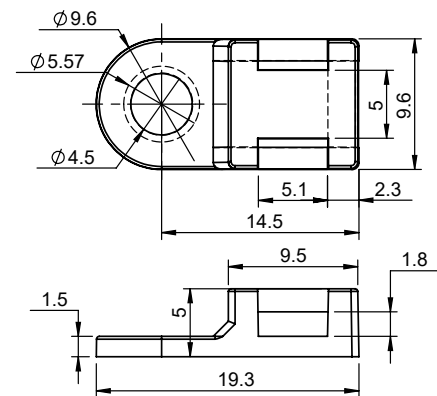

**D S C H**

- Halogen Free
- 100% MADE IN INDIA
- Standard Color - White & Black
- Made out of Virgin Engineering Plastic
- UV Resistant Cable Ties are also available

## Storage:

- The ideal storage temperature is around 23° with the humidity over 50%
- Do not expose directly under sunlight except UV resistant cable ties.
- Do not open the bag before use. Try and finish the whole package of cable ties once it's opened. Seal the bag of remaining pieces to maintain the quality
- Avoid storing cable ties in hot/warm conditions to avoid colour change

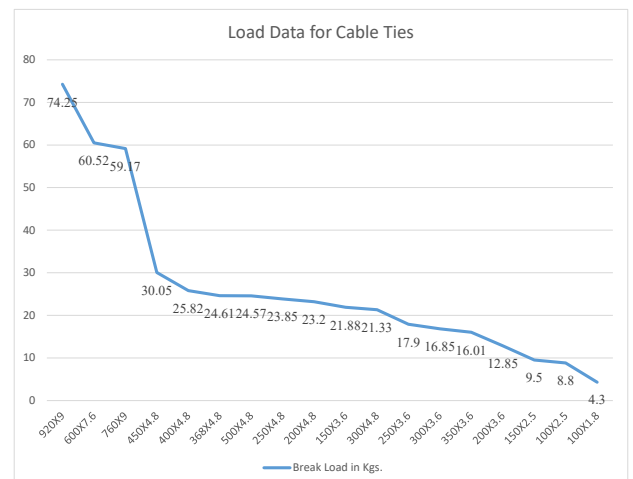

XI

I

II

III

IV

V

VI

VII

VIII

IX

X

XI

XII

XIII

XIV

# CONDUIT ACCESSORIES & CABLE TIES

## Cable Ties

Polyamide

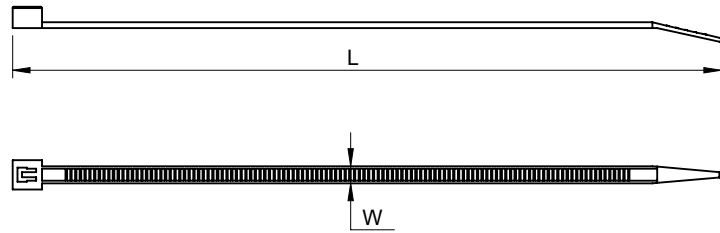

**C** Colour  
**N** Natural  
**B** Black

Length (L)	Width (W)
100	1.8
100	2.0
100	2.5
150	2.5
150	3.6
200	2.5
200	3.6
200	4.8
200	7.6
250	3.6
250	4.8
300	3.6
300	4.8
300	7.6
350	3.6
350	4.8
368	4.8
370	4.8
400	4.8
450	4.8
450	7.6
500	4.8
530	7.6
600	7.6
600	9.0
760	9.0
920	9.0
1000	9.0

Note: Other colour options available at Minimum Order Quantities

XI



I



II



III



IV



V



VI



VII



VIII



IX



X



XI



XII



XIII



XIV

# Ideas





## Darshana Industries Pvt. Ltd.

📍 Head Office & Factory:  
Sub Plot No. 32, Final Plot No. 6,  
Ramtekdi Industrial Estate, Hadapsar,  
Pune-411 028. Maharashtra, INDIA.

☎ Tel: +91 20 2951 1572

🌐 [darshanaindustries.com](http://darshanaindustries.com)

Head of Sales & Exports

👤 **Sanket Sutrave**  
✉ [ssutrave@darshanaindustries.com](mailto:ssutrave@darshanaindustries.com)

Head of Business Development

👤 **Jethan Reddy**  
✉ [jmadhireddy@darshanaindustries.com](mailto:jmadhireddy@darshanaindustries.com)

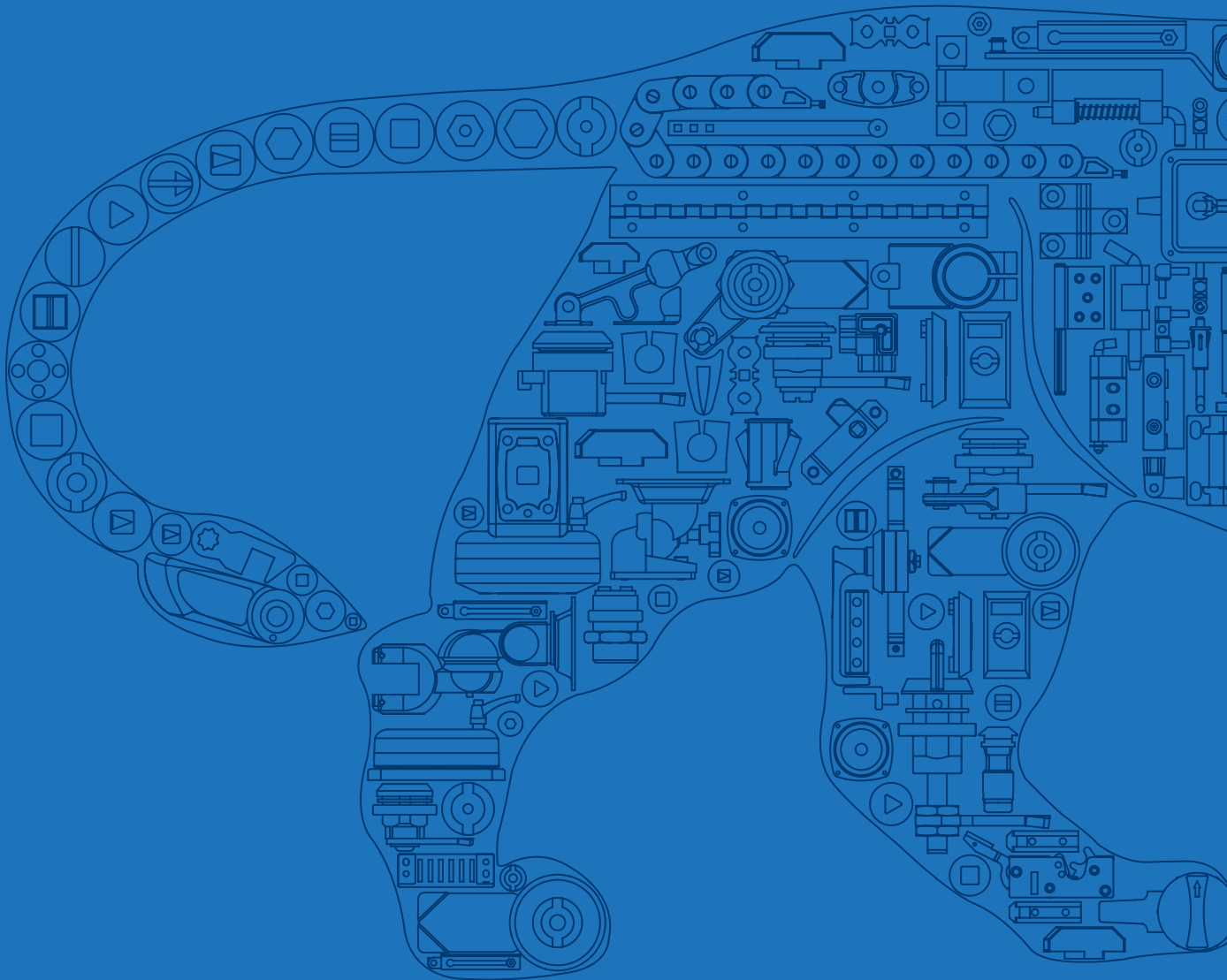

Made in India 🌐 Made for You