

D darshana®

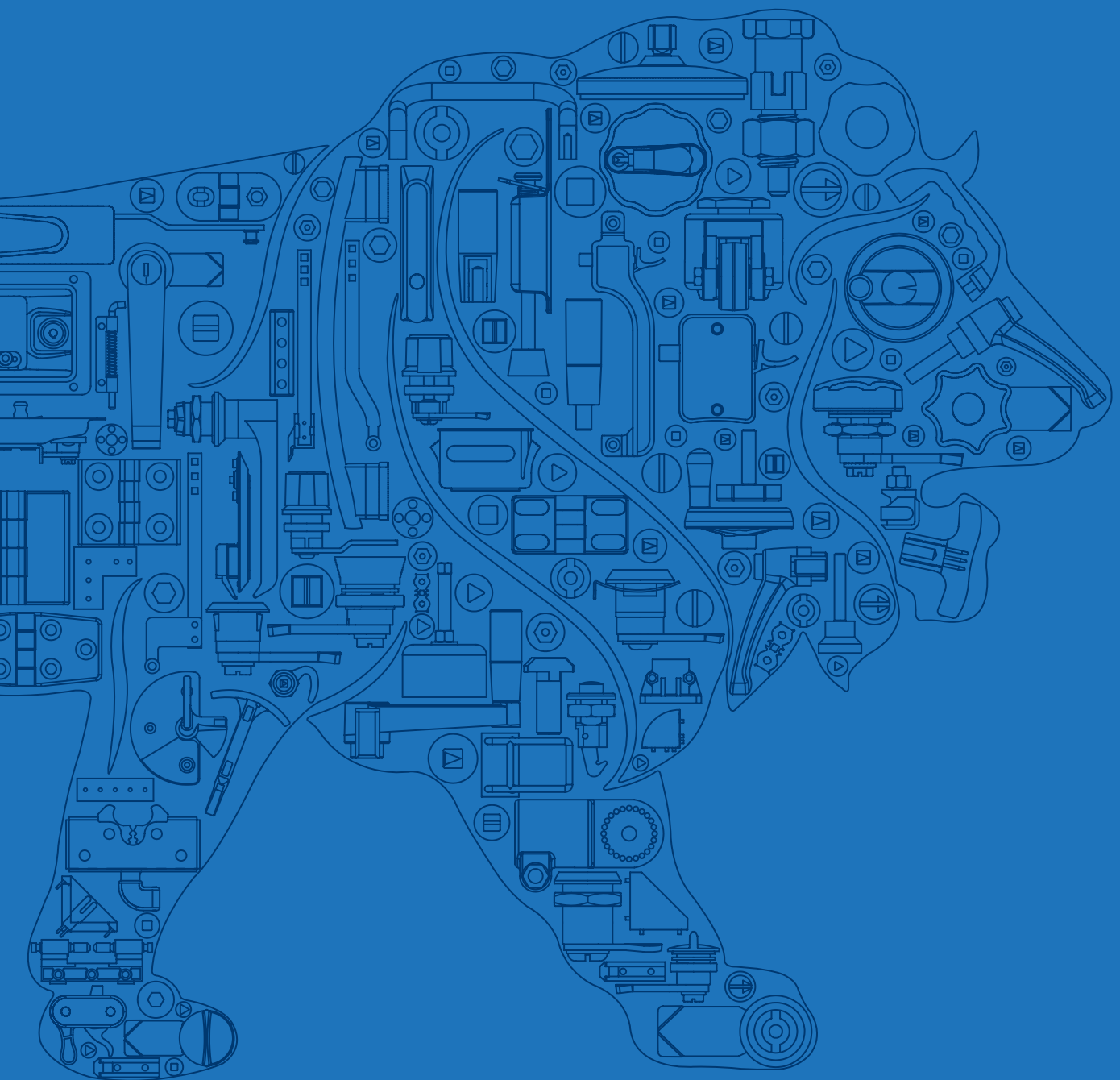

Made in India  Made for You

WHO WE ARE

India's Largest and Most Trusted Manufacturer of
Access Hardware and Machine Components

Founded in
1982

Highly focused on
INDIA'S
Strong Machine
Building Industry

Engineering

Tooling

Manufacturing

Sales

Two Locations in
PUNE

120,000 sq. ft.
(11,000 sq. m.)
AREA

OVER 350

People Committed to Customer Satisfaction

OVER 20 DEALERS

in India and reliable partners overseas to provide end to end
integration of parts in customer's designs

OVER 90%

of components used are

MADE-IN-HOUSE

Ensures control of quality and delivery

OUR PRESENCE IN VARIOUS SECTORS



Agriculture



Airline Industry



Automation



Automobile



Dairy



Defence



Earthmoving



Electric Panels



Food



Generator



Hospital Essentials



HVAC



Interior



Kitchen Equipment



Machine Building



Marine



Medical



Office Furniture



Pharma



Printing & Packing



Railways



Renewable Energy



Telecom



Waste Management

OUR GLOBAL PRESENCE

India

- Ahmedabad
- Aurangabad
- Bengaluru
- Chennai
- Coimbatore
- Delhi
- Goa
- Hyderabad
- Indore
- Kolhapur
- Mumbai
- Nagpur
- Nashik
- Noida
- Pune
- Punjab
- Rajkot
- Surat
- Vadodara

International

- Australia
- Canada
- Egypt
- France
- Iceland
- Ireland
- Israel
- Italy
- Kenya
- Kuwait
- Lebanon
- Malaysia
- Netherlands
- New Zealand
- Nigeria
- Oman
- Philippines
- Poland
- Saudi Arabia
- South Africa
- Spain
- Sri Lanka
- Thailand
- UAE
- United Kingdom
- Yemen
- Zambia
- USA

Vision

To be the leading trusted source of engineered machine components.

Mission

To create continuous growth opportunities through value driven product designs and operations.
We will achieve this growth through well engineered designs that ensure product reliability and efficient manufacturing operations that are committed to quality, consistency, and cost management
Customer connectivity that creates long-term relationships

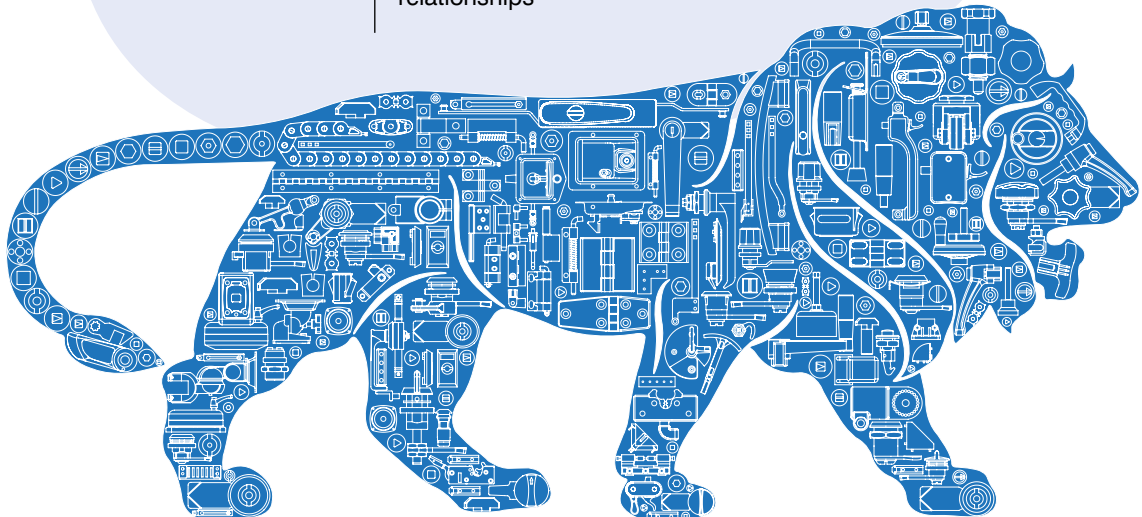

Made in India  Made for You



Primary Processes in Facility 1

- Zinc Die Casting
- Injection Molding
- Powder Coating
- Laser Cutting
- CNC Machining
- Gasketing
- Key Making
- Robotic Welding
- Robotic Buffing
- Automated Assembly Lines

ISO CERTIFIED

9001 : 15 | 14001 : 15 | 45001 : 15

Primary Processes in Facility 2

- Stamping Unit
- Riveting Line
- Secondary Finishing Lines
- Assembly (Sheet Metal Components)
- Space for expansion

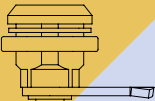
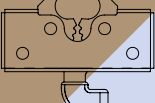
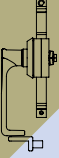
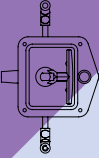
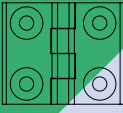
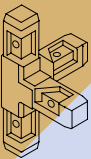

Product Categories

Colour coding for Category identification	Product Category	Category Sub Colour Shade	Page No.
 Category Number I	HANDLES		008 to 083
 Category Number II	LOCKS		084 to 119
 Category Number III	LATCHES		120 to 145
 Category Number IV	MULTI-POINT LOCKS		146 to 179
 Category Number V	CANOPY LOCKS		180 to 195
 Category Number VI	HINGES		196 to 267
 Category Number VII	CONVEYOR COMPONENTS		268 to 291

Part Code Configurator



For building the **Part Code** please fill the variables that are outlined values from the table referring the drawings.

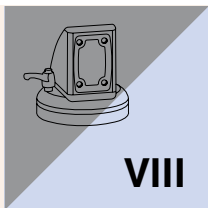

SUPPORT ARM SYSTEM

292 to 323

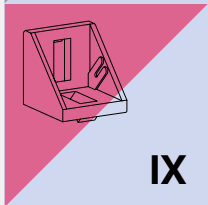

ALUMINIUM SECTIONS & ACCESSORIES

324 to 343

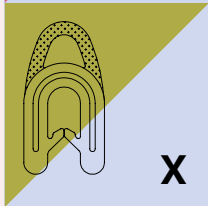

GASKETS

344 to 349

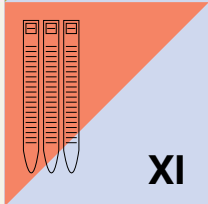

CONDUIT ACCESSORIES & CABLE TIES

350 to 355

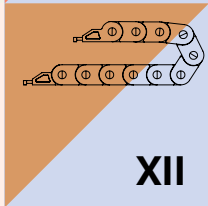

DRAG CHAINS

356 to 361

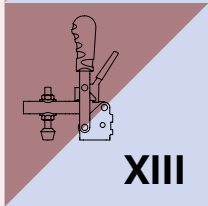

TOGGLE CLAMPS

362 to 379

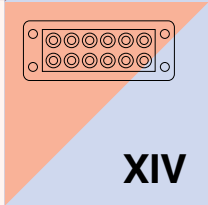

CABLE MANAGEMENT SYSTEM

380 to 385

Part Code Index

Product Name	Material	Page
Aluminium Section	Aluminium	326
		327
End Caps	Polyamide	328
Hammer Nut	Zinc, MS	329
		329
	MS	330
Spring Nut	Zinc, MS	331
Hammer Screw	MS	
Blind Bracket	Zinc	332
		333
		334
Straight Joint	Zinc, MS	335
Flexible Joint		
Right Angle Bracket	Zinc, MS	336
	Zinc	337
	MS	338

Product Name	Material	Page
Right Angle Bracket	Zinc	339
Profile Cover	PVC	
Pivot Joint	Zinc	340
Base		341
Right Angle Bracket	Aluminium	342
Standard Accessories	Polyamide	343

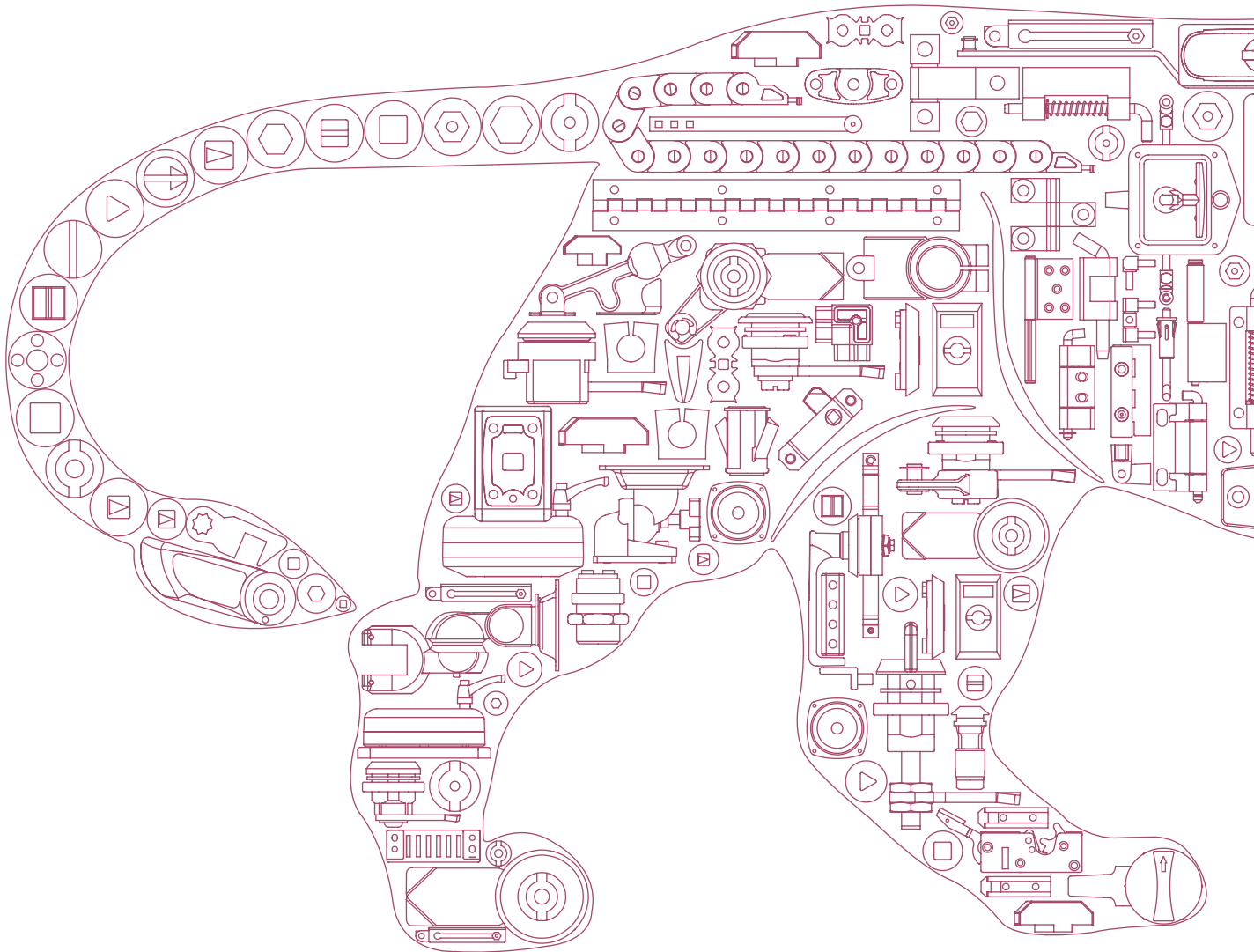

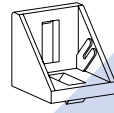

IX

ALUMINIUM SECTIONS & ACCESSORIES

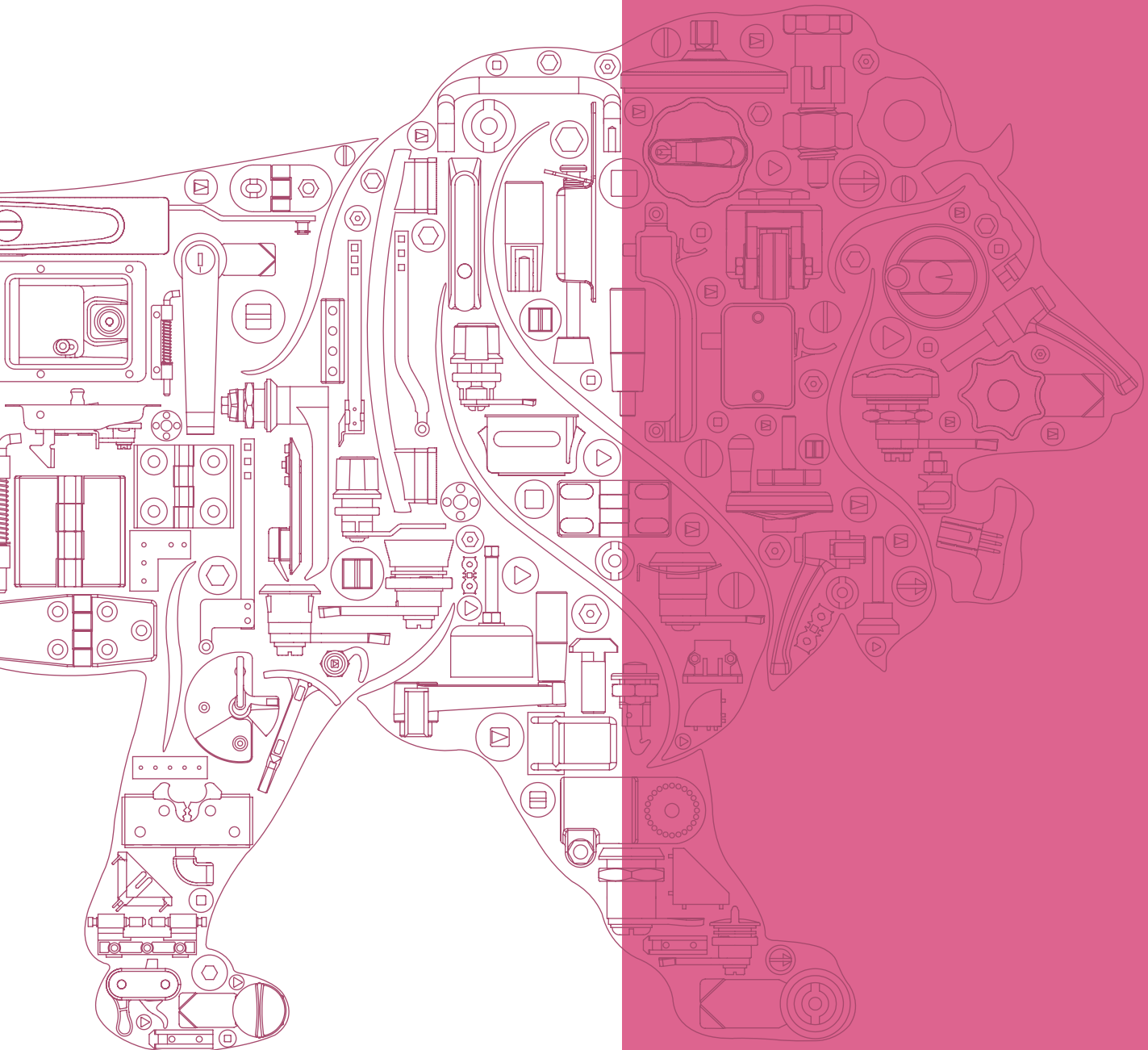

Made in India  **Made for You**

ALUMINIUM SECTIONS & ACCESSORIES

Aluminium Section

Aluminium

IX

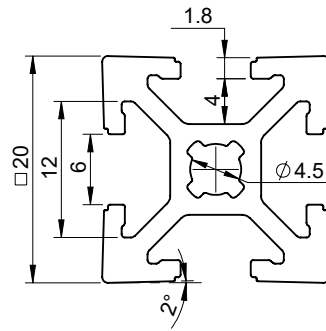

DALP-200

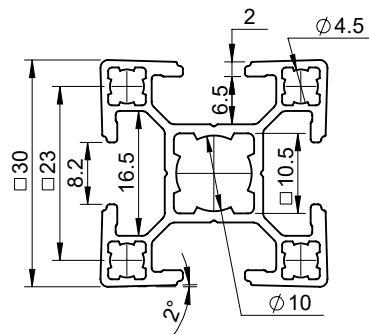

DALP-3030M

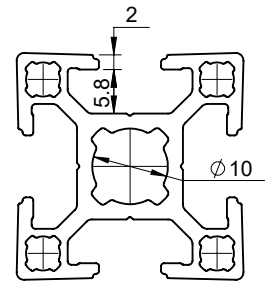

DALP-3030H

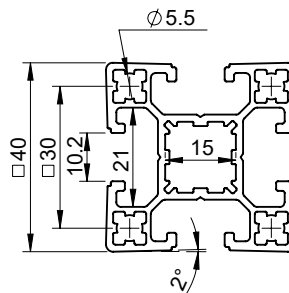

DALP-4040L

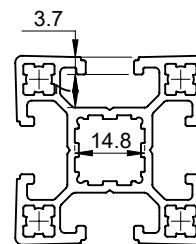

DALP-4040M

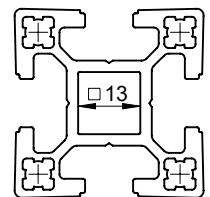

DALP-4040H

ALUMINIUM SECTIONS & ACCESSORIES

Aluminium Section

Aluminium

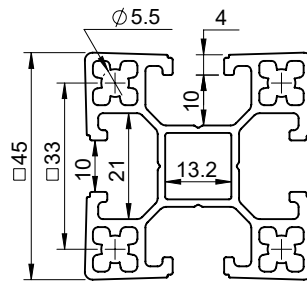

DALP-4545M

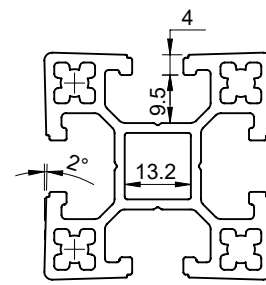

DALP-4545H

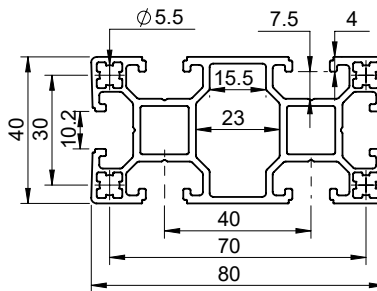

DALP-4080M

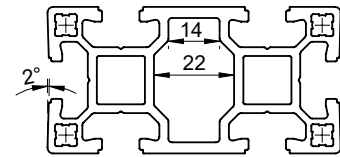

DALP-4080H

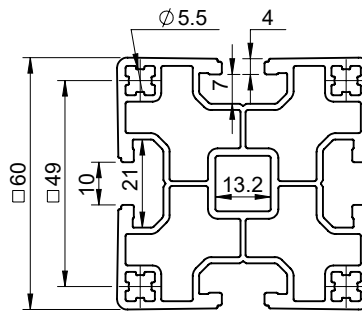
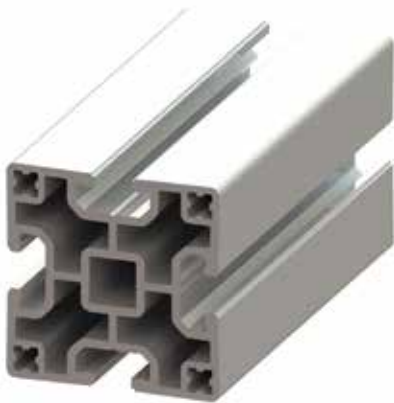

DALP-6060-M

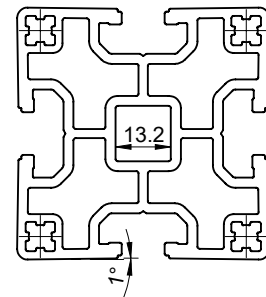

DALP-6060-H

IX



I



II



III



IV



V



VI



VII



VIII



IX



X



XI



XII



XIII



XIV



ALUMINIUM SECTIONS & ACCESSORIES

End Caps

Polyamide



APC-20D



APC-20R



APC-30



APC-30B



APC-40B



APC-40S



APCS-40



APC-45B



APC-80P



APC-80S

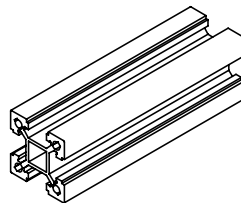

Without Cap (Application)

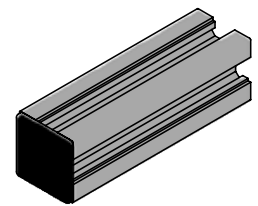

With Cap (Application)

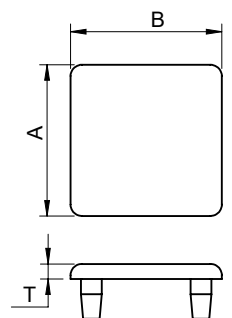

Product Code	Material	Section Size	A	B	T	Description
APC-20D	Polyamide	20 X 20	20	20	3	END CAP
APC-20R						
APC-30		30 X 30	30	30	3.3	
APC-30B						
APC-40B		40 X 40	40	40	4	
APC-40S						
APCS-40		45 X 45	45.5	45.5	5.2	
APC-45B						
APC-80P		80 X 40	40	80	4	
APC-80S						

ALUMINIUM SECTIONS & ACCESSORIES

Hammer Nut

Zinc, MS

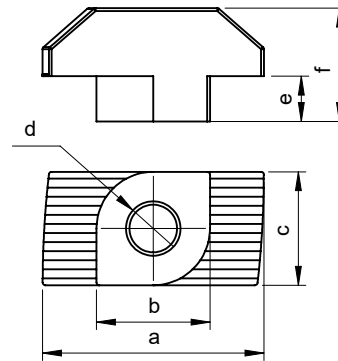

A P X M - d

<input checked="" type="checkbox"/>	a	b	c	d				e	f
1	19.5	10	10	M4	M5	M6	M8	4	10
2	16.5	8	8	M4	M5	M6		1.5	6.5
3	13.3	10	10	M4	M5	M6	M8	3	6.5
4	11	6	6	M4				1.7	5.5
5	17.4	9.5	14	M6		M8		5.5	9.5

Add "M" only for Metal Plugs

Hammer Nut

Zinc, MS

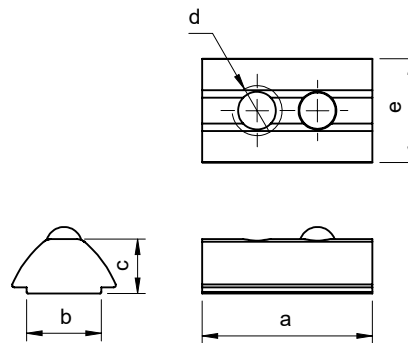

A P 6 - d

a	b	c	d		e
22.5	9.9	7.2	M6	M8	13.2

IX



I



II



III



IV



V



VI



VII



VIII



IX



X



XI



XII



XIII



XIV



ALUMINIUM SECTIONS & ACCESSORIES

Hammer Nut

Zinc, MS

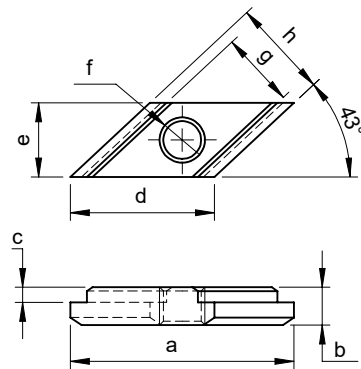

A P 9 M - X - f

X	a	b	c	d	e	f		g	h
30	27	3	2	18	9.8	M6	M8	10	13
40	31	9	4.8	21	9.6	M6	M8	10	15

Hammer Nut

MS

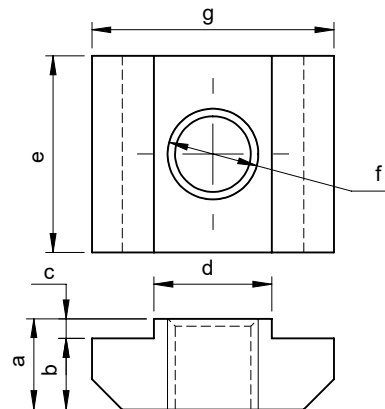

A P X M - f

X	a	b	c	d	e	f		g
10	6	4.7	1.3	8	13	M6	M8	16
11	5	3.2	1.8	9.8	13	M6	M8	13

ALUMINIUM SECTIONS & ACCESSORIES

Spring Nut

Zinc, MS

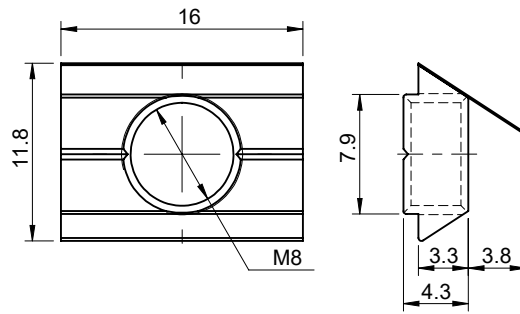

A	P	C	12	M	-	M	8
---	---	---	----	---	---	---	---

Hammer Screw

MS

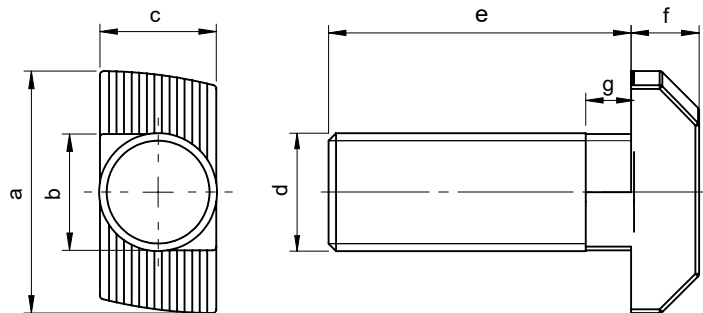

A	P	X	M	S	-	M	8	x	20
---	---	---	---	---	---	---	---	---	----

X	a	b	c	d	e	f	g
15	16	7.7	7.7	M8	20	4.5	3
16	19	9.9	8.5			5.8	

IX



I



II



III



IV



V



VI



VII



VIII



IX



X



XI



XII



XIII



XIV



ALUMINIUM SECTIONS & ACCESSORIES

Blind Bracket

Zinc

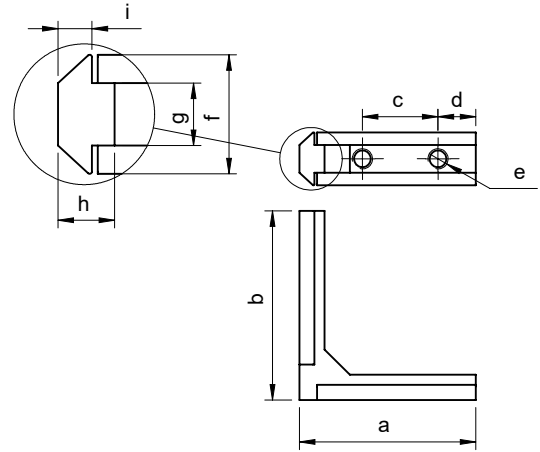

A F X - 3320 D

X Mounting Style

- I** Internal Mounting
- O** Outer Mounting

X	a	b	c	d	e	f	g	h	i
I	35	38	14	7.5	M4	11	6	5.3	3.5
O	33.5	39	13.5	9					

Blind Bracket

Zinc

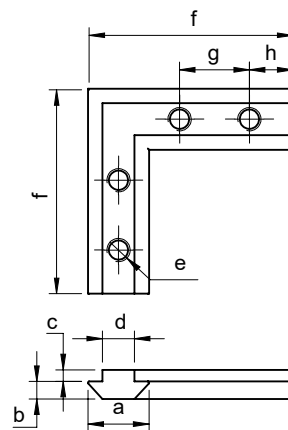

A F F - 33 X D

X	a	b	c	d	e	f	g	h
20	11	3.3	2	6	M4	35	14	7.5
30	14	3	4	9.8	M6	40		

ALUMINIUM SECTIONS & ACCESSORIES

Blind Bracket

Zinc

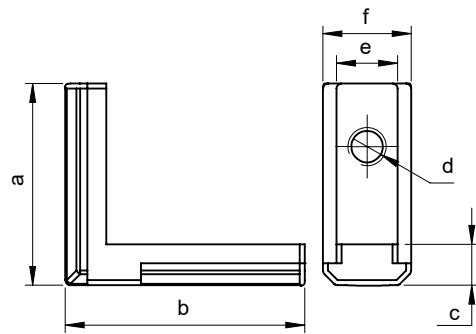

A	F	X	-	3330	D
---	---	---	---	------	---

X Mounting Style

- I** Internal Mounting
- O** Outer Mounting

X		a	b	c	d	e	f
I	O	32	35	38	7.5	M6	15.5

Blind Bracket

Zinc

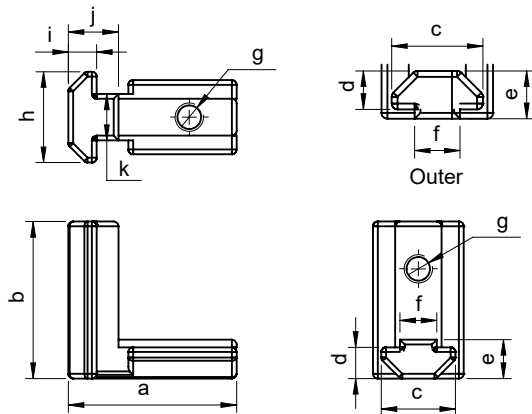

A	F	X	-	3040	D
---	---	---	---	------	---

X Mounting Style

- I** Internal Mounting
- O** Outer Mounting

X		a	b	c	d	e	f	g	h	i	j	k
I	O	35.6	33	15.7	6.6	8.2	7.8	M6	19	6	10.6	9.8

IX



I



II



III



IV



V



VI



VII



VIII



IX



X



XI



XII



XIII



XIV



ALUMINIUM SECTIONS & ACCESSORIES

Blind Bracket

Zinc

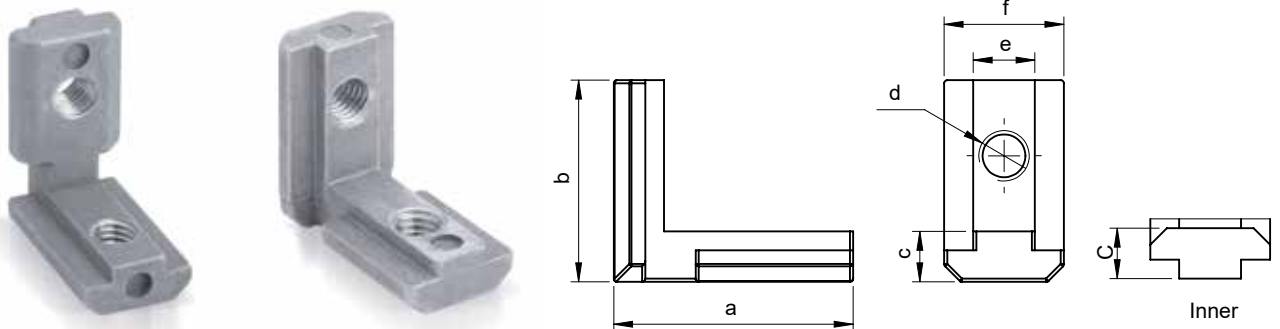

A F X - 33 Y D

X Mounting Style

- I Internal Mounting
- O Outer Mounting

X		Y	a	b		c	d	e	f
I	O	40	38	32	35	8	M8	9.8	19
		45				9			19.5

Straight Joint

Zinc

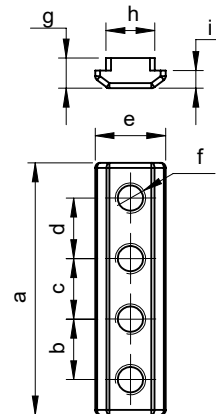

A F E - X

X	a	b	c	d	e	f	g	h	i
30D	50	12	12	12	14	M6	6	9.7	3.5
3320D		14	10	14	11	M4	5.4	6	
4045	60	13.7	13.7	13.7	17	M6	9.5	9.5	5.5

IX



I



II



III



IV



V



VI



VII



VIII



IX



X



XI



XII



XIII



XIV

ALUMINIUM SECTIONS & ACCESSORIES

Flexible Joint

Zinc

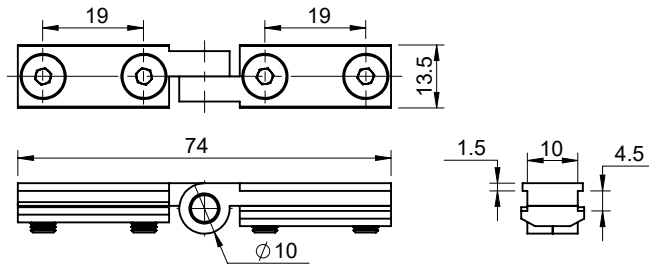

A	F	E	J	-	40
----------	----------	----------	----------	----------	-----------

Right Angle Bracket

Zinc, MS

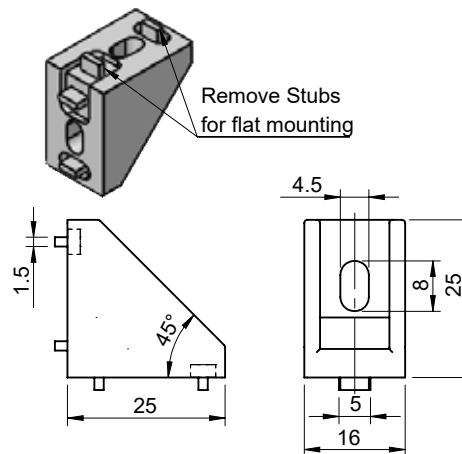

A	F	2	W	-	20
----------	----------	----------	----------	----------	-----------

IX



I



II



III



IV



V



VI



VII



VIII



IX



X



XI



XII



XIII



XIV

ALUMINIUM SECTIONS & ACCESSORIES

Right Angle Bracket

Zinc

IX

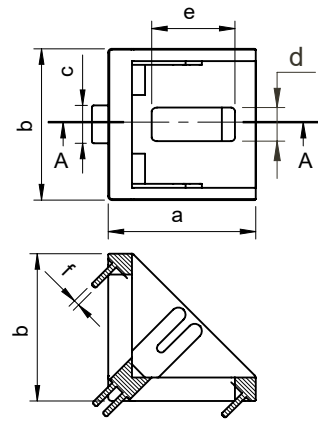

A F 2 W - X

X	a	b	c	d	e	f
30B	27.5	28	8	M6	11.3	1.3
40B	39	40	10.2	M8	22	

Add "C" after "W" for ordering part with Cap

Right Angle Bracket

Zinc

X

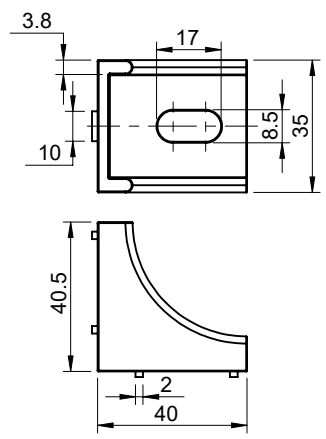

A L F 2 W - 45

ALUMINIUM SECTIONS & ACCESSORIES

Right Angle Bracket

Zinc

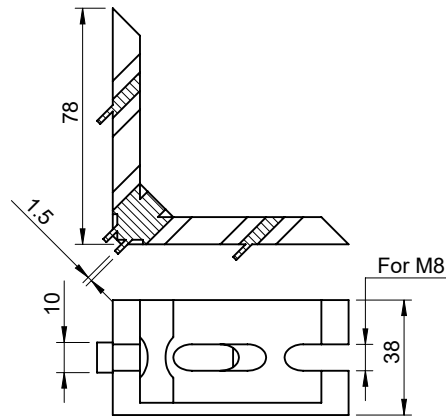

A	F	2	W	-	80
----------	----------	----------	----------	----------	-----------

Right Angle Bracket

Zinc

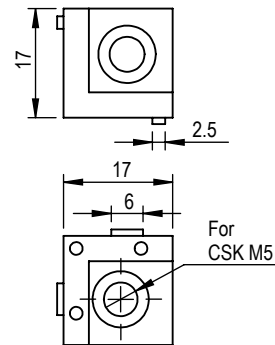

A	F	3	W	-	20
----------	----------	----------	----------	----------	-----------

IX



I



II



III



IV



V



VI



VII



VIII



IX



X



XI



XII



XIII



XIV

ALUMINIUM SECTIONS & ACCESSORIES

Right Corner Joint

Zinc

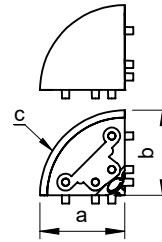

D F T A - X

<input checked="" type="checkbox"/>	a	b	c
20	20	20	R20
30	30	33	R30.5
40	40	43	R40.5

Add "C" after "A" for ordering part with Cap

Heavy Duty Joint

MS

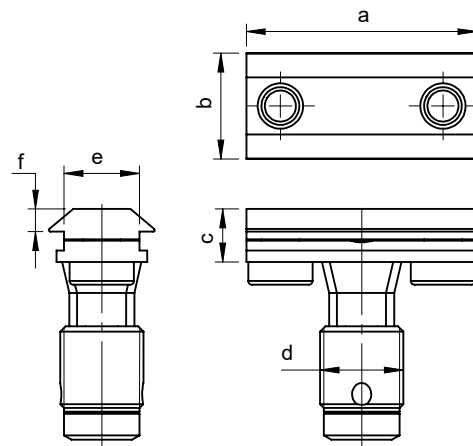

D F R - X

<input checked="" type="checkbox"/>	a	b	c	d	e	f
30P	30.5	14	7	M11	10	3
40P	37.5	13.5	9.1	M14		

IX



I



II



III



IV



V



VI



VII



VIII



IX



X



XI



XII



XIII



XIV

ALUMINIUM SECTIONS & ACCESSORIES

Right Angle Bracket

Zinc

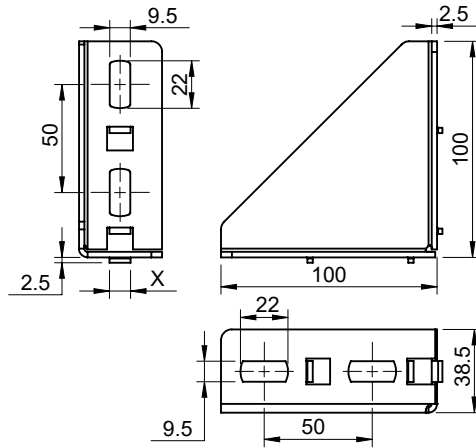

A F 2 W M 1 - 40 - X - F

X	F	Material
9.8	PC	MS
7.8	SPC	

Profile Cover

PVC

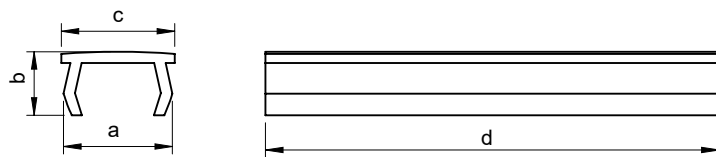

D P A X - Y - F

X	Y	F			a	b	c	d
4	8	Blue	Black	Gray	9.6	5.6	10	2.0 mtr. (Std)
5	10				11.6	7	12.3	

IX



I



II



III



IV



V



VI



VII



VIII



IX



X



XI



XII



XIII



XIV



ALUMINIUM SECTIONS & ACCESSORIES

Pivot Joint

Zinc

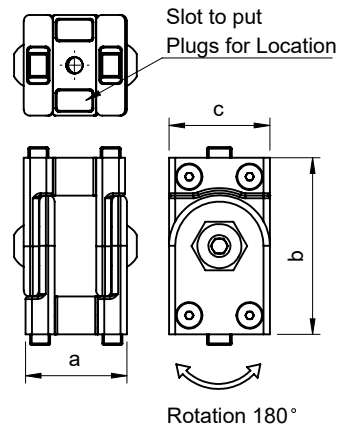

D F P - X

X	a	b	c
4040	40	70	40
4080	80	70	40

Base

Zinc

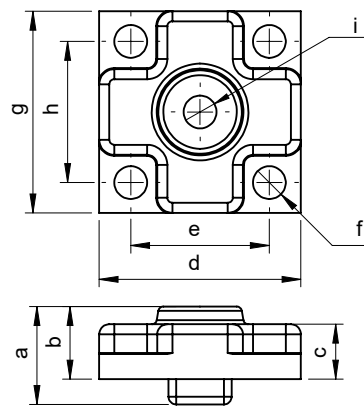

A L B1 - i

a	b	c	d	e	f	g	h	i		
18.5	13.5	10	40	28	Ø6.5	40	28	M8	M10	M12

IX

I

II

III

IV

V

VI

VII

VIII

IX

X

XI

XII

XIII

XIV

ALUMINIUM SECTIONS & ACCESSORIES

Base

Zinc

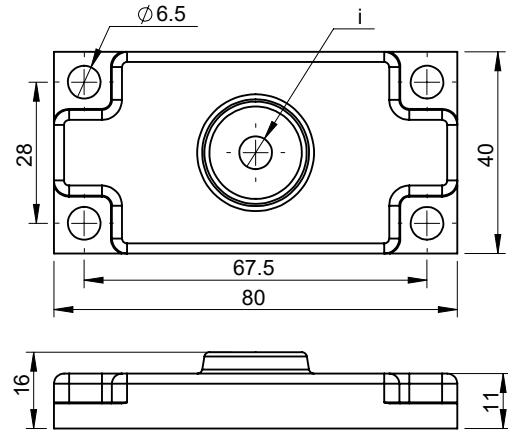
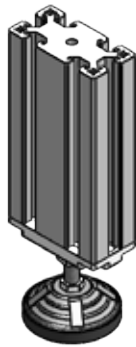

A L B 2 - i

i		
M8	M10	M12

Base

Zinc

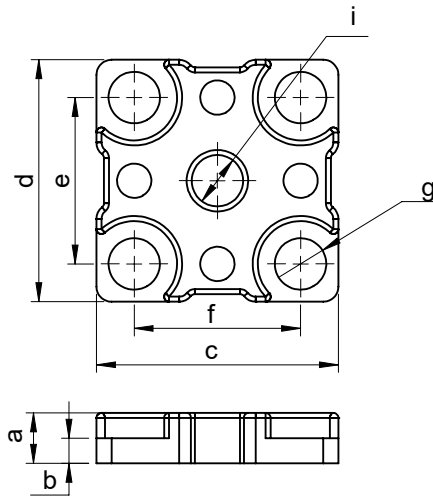

A L B X - i

X	a	b	c	d	e	f	g	i
4	10	5	48		33		Ø10.2	M12
5	9	2.3	40		30		Ø6.4	M10

IX



I



II



III



IV



V



VI



VII



VIII



IX



X



XI



XII



XIII



XIV



ALUMINIUM SECTIONS & ACCESSORIES

Right Angle Bracket

Aluminium

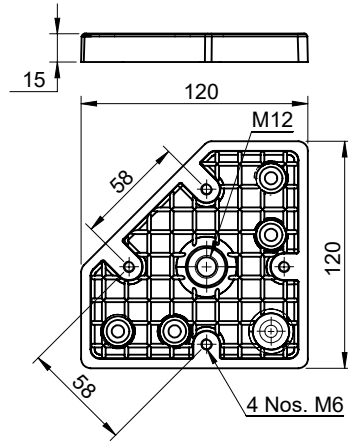

A	L	B	3	-	M	12
---	---	---	---	---	---	----

Standard Accessories

Polyamide

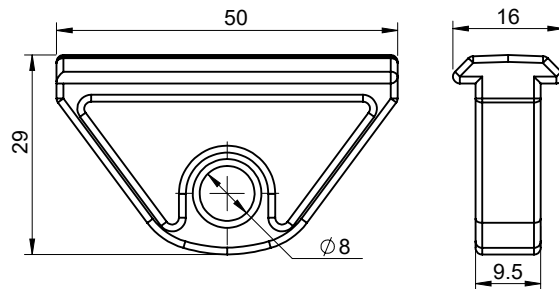

A	S	H	-	10
---	---	---	---	----

ALUMINIUM SECTIONS & ACCESSORIES

Standard Accessories

Polyamide

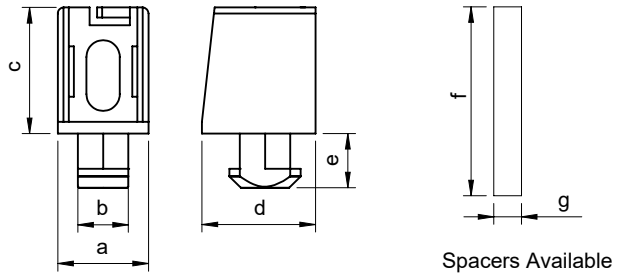

A P M - X - M6

X	a	b	c	d		e
30	23.97	13.5	15.6	7.7	6.7	18
40	23.95	15.5	23.7	9.7	8.5	20

Standard Accessories

Polyamide

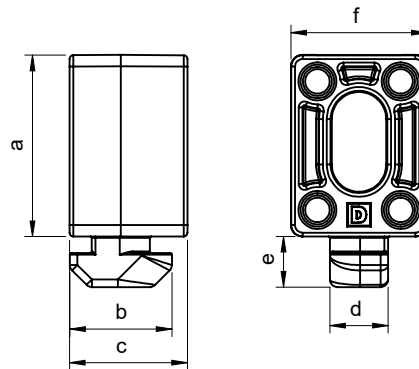

A P 2 M - M6

IX



I



II



III



IV



V



VI



VII



VIII



IX



X



XI



XII



XIII



XIV



Ideas



Darshana Industries Pvt. Ltd.

📍 Head Office & Factory:
Sub Plot No. 32, Final Plot No. 6,
Ramtekdi Industrial Estate, Hadapsar,
Pune-411 028. Maharashtra, INDIA.

☎ Tel: +91 20 2951 1572

🌐 darshanaindustries.com

Head of Sales & Exports

👤 **Sanket Sutrave**
✉ ssutrave@darshanaindustries.com

Head of Business Development

👤 **Jethan Reddy**
✉ jmadhireddy@darshanaindustries.com

